



INSTRUMENTS, INC.

468 Liberty Drive
Wittenberg, WI 54499
U.S.A.

Tel: 715- 253-2801 Ver.11-01-2008
Fax: 715- 253-2811
Web: www.solar.imcinstruments.com

REV. 4-1-2012

EMP1 OPERATING & INSTALLATION INSTRUCTIONS

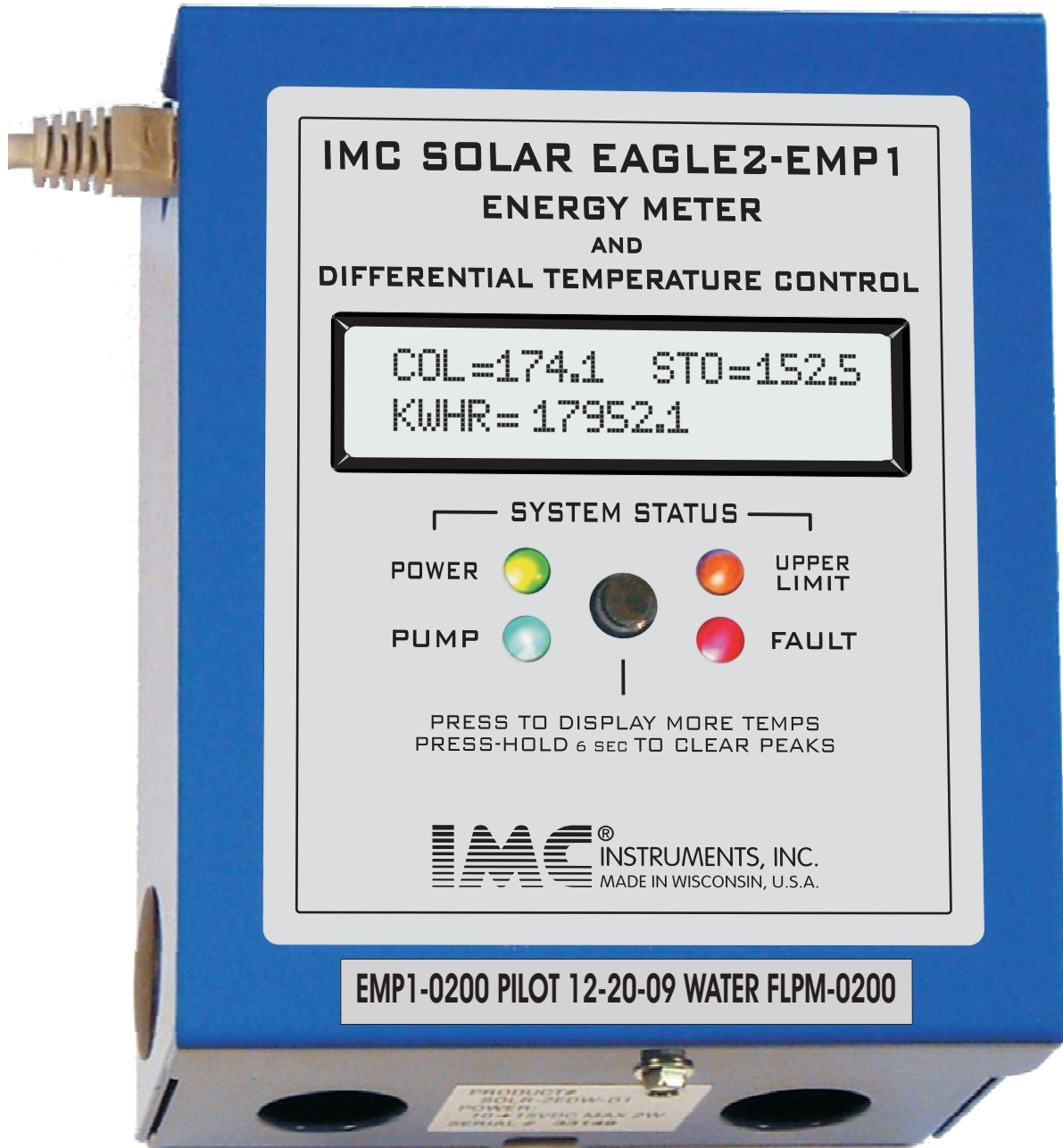

INSTRUMENTATION WITH QUALITY ENGINEERING



EMP1 OPERATING & INSTALLATION INSTRUCTIONS

TABLE OF CONTENTS

PG 2	TABLE OF CONTENTS
PG3	PRODUCT DESCRIPTION
PG4	PERFORMANCE SPECIFICATIONS AND OIML R-075 CERTIFICATE OF CONFORMANCE
PG6	SIZE 2" - MODEL FLPM-0200 FLOW METER
PG8	SIZE 1" - MODEL FLPM-0100 FLOW METER SIZE 1 ½" - MODEL FLPM-0150 FLOW METER
Pg10	SIZE 3/4" - MODEL FLPM-0075 FLOW METER
Pg12	ENERGY METER SETUP INSTRUCTIONS
Pg13	INSTALLATION AND OPERATING INSTRUCTION FOR FLOW METERS MODELS FLPM & FLPH

IMC EAGLE 2 DIFFERENTIAL CONTROLLERS / ENERGY METER

The IMC EAGLE 2 DIFFERENTIAL CONTROLLERS with built in BTU METERS are being sold only to qualified Distributors as PROJECTS "one at a time". These "projects" as we call them today, are fully functional products minus a few future features such as a 5th sensor for top of tank temperature monitoring and so on. They include a full featured EAGLE 2 WEB Differential Controller with an isolated serial interface which can be permanently connected to a PC for data logging and a FLOW meter "plug and play" interface. The following are the sizes of flow meters that are available : 3/4", 1", 1-1/2" and 2" . Please see pgs 4-9. The controller has 4th and a 5th pages on the display that includes GPM and Kilo-watt hours of collected energy. It is FLASHED into permanent memory every 20 minutes incase of power failures. The customer has to read the KILOWATT HOUR METER value and record it every month or at any other interval he wishes. He can also reset the Kilo watt hour counter to ZERO if he follows the RESET instructions. The BTU calculations have been carefully programmed to take into account the effects of Glycol-water mixtures. The Processors are permanently programmed to a specific percentage of Propylene Glycol present in the heat transfer solution from 0 % to 100%.

We supply Precision MATCHED sensors to with in 0.2F which are essential for accurate BTU calculations. The matching was been tested and verified over the range of 80F to 210F in our precision temperature baths for each set of sensors supplied with each BTU / CONTROLLER. Connecting cables to both sensors have to also be matched with in 1.5 ohms of each other in the field. Cable length equivalency = 18Ga.>75', 20Ga.>35', 22Ga.>20 feet For your information most of these initial systems are being connected to WIRED SOLAR for WEB monitoring and PUBLISHING. A very impressive marketing TOOL. There is now a stand alone PC based software package "SOLAR-BTU-LOG" that can be installed in a local PC to monitor and DATA log in graphical form the entire solar installation. This information is available for download directly from our website at www.solar.imcinstruments.com.

```
15:01:15 ET=64:34:43 Communication Port Not Active
Last Data Received:
High Limit 0.0 Differential 0.0
Pump is OFF On_Hours=19.36 Duty_Cycle= 0.30 Cycles=4
Samples=23226 Samples saved=801 Samples Logged=0 Open_Sensors=0 Data_Errors=0
Quantity Current Maximum Minimum Day Max Day Min
Collector 60.2 158.8 34.2 154.3 34.2
Storage 114.8 135.8 83.5 130.5 84.5
Aux-1 96.1 143.6 70.5 137.0 71.3
Aux-2 87.3 134.7 68.7 129.2 70.2
BTUs Captured 462274.1 157217.4
KWHs Captured 135.4 46.1
BTU/hour 0.0 32650.1 32280.3
```

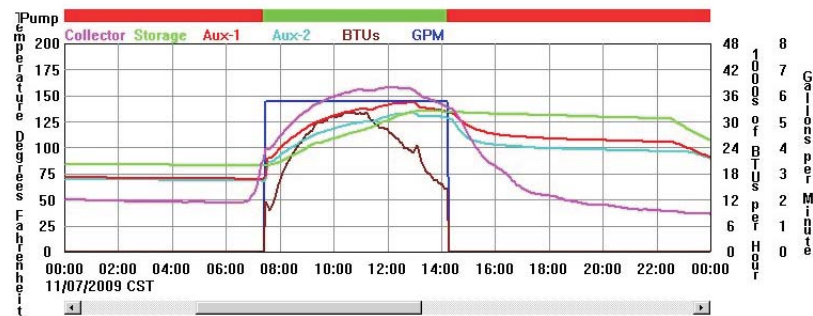

SOLAR "BTU" CHARTING / LOGGING SOFTWARE

REV. 3-15-11

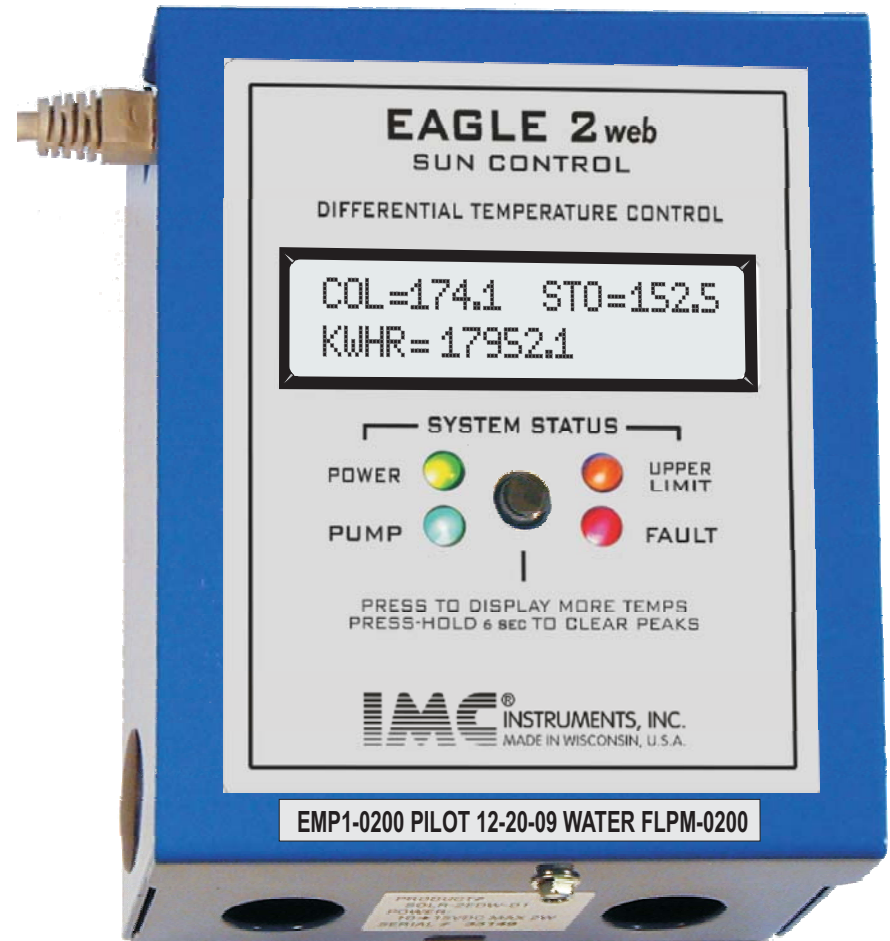

Line Corded models also available

IMC® INSTRUMENTS, INC.
WITTENBERG WI



INSTRUMENTS, INC.

468 Liberty Dr.
Wittenberg, WI, 54499,
USA

TEL 715- 253 2801
715- 445 4946
FAX 715- 253 2811

THERMAL ENERGY METER MODEL # EAGLE 2 PILOT BTU

REV. 3-15-11

PERFORMANCE SPECIFICATIONS

The ENERGY METER shall consist of the following :

1) Flow meter having an error no greater than 2.0 % over the measuring range from its minimum transitional flow Q_{tr} to its maximum normal operating flow Q_n . See below

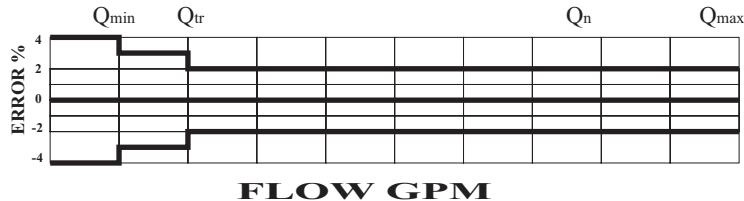

The flow meter must have test certificates showing conformance to the above required accuracies by approved test methods or labs. In order to minimize other possible sources of error, installation guide lines for proper fluid entry and exit to the flow meters must be strictly adhered to.

For Physical and Electrical specifications please refer to attached Flow meter specifications and or Literature.

2) Two Precision Matched IMMERSION Temperature sensors with a temperature difference error no greater than 0.2 degrees F from a measured temperature of 77 F (25C) to 220 F (104.4C). Insure that the temperature sensors are properly exposed to the heat transfer fluid media and insulated from the effects of external temperatures. The Temperature sensors must have a test certificate that is NIST traceable showing conformance to the stated accuracies of this specification .

3) Differential Solar Temperature Controller with four-matched temperature channels and a built in ENERGY METER TOTALIZER using the precision sensors and the flow meter to provide a sum total of the accumulated thermal energy to be displayed in a continuous RUNNING TOTAL of Electrical equivalent of thermal energy expressed in KILOWATT HOURS. The sum total can be manually reset to Zero only. No other alterations to the VALUE are possible. For Physical and Electrical specifications please refer to attached Flow meter specifications and or Literature.

4) Energy Computer to calculate and Totalize the Thermal Energy elements with a maximum of a 17 second interval frequency. The calculations must follow well-established calorimetry mythology as set forth by the ASHRAE HAND BOOK of FUNDAMENTALS. Physical constants for the heat transfer fluid must be accurately defined for the Density and Specific Heat of the heat transfer fluid every 10 degrees F from a temperature of 77 F (25C) to 220 F (104.4C) and must be included in the energy content calculations. If Glycol is part of the Heat Transfer fluid, the Density and Specific Heat constants obtained from a recognized Laboratory must also be included in accordance with the water to Glycol mixture and temperatures that the fluid is at when the energy measurements are made.

a) The Kilowatt-Hours readings will be stored in the energy computer's PERMANENT memory and retained for a period of at least 12 years. NO BATTERIES ARE REQUIRED. The maximum number of Kilowatt-Hours is 830,000 at which time the contiguous counter will reset to ZERO and start over again.



INSTRUMENTS, INC.

468 Liberty Dr.
Wittenberg, WI, 54499,
USA

TEL 715- 253 2801
715- 445 4946
FAX 715- 253 2811

PERFORMANCE SPECIFICATIONS cont

b) The over all accuracy of the Thermal Energy meter is dependant on the magnitude of the heat transfer fluid temperature increase thru the solar collection as follows:

Temp Diff	Flow Mtr Error	Sensor error	Calculator error	MAXIMUM TOTAL error
50.0 F **	+/- 2.0% Max	+/-0.10F/50.0 = 0.2%	+/- 0.4%	2.6%**
14.0 F	+/- 2.0% Max	+/-0.10F/14.0 = 0.7%	+/- 0.4%	3.1%
11.2 F	+/- 2.0% Max	+/-0.10F/11.2 = 0.9%	+/- 0.4%	3.3%
7.5 F	+/- 2.0% Max	+/-0.10F/7.5 = 1.3%	+/- 0.4%	3.7%
4.0 F**	+/- 2.0% Max	+/-0.10F/4.0 = 2.5%	+/- 0.4%	4.9%**
3.5 F	+/- 2.0% Max	+/-0.10F/3.5 = 2.8%	+/- 0.4%	5.2%

-- Currently The following PROPYLENE GLYCOLS are approved and stored in our computers for use with IMC ENERGY METERS ... Dow Frost-HD -The Dow Chemical
No Burst-HD - The Noble Company

As other Glycols are approved they will be characterized and entered into the IMC Energy METERS.
Please contact the factory for additional information

**Note values used to show OIML compliance

CERTIFICATE OF COMPLIANCE

for IMC Energy Meters

EMP1-0050

EMP1-0075

EMP1-0100

EMP1-0150

EMP1-0200

With OIML R 75-1 Specification

Date: 15 May 2010

Certifying engineer

Engineering Manager- IMC Instruments
468 Liberty Drive, Wittenberg, WI 54499
Tel: 715-253-2801

FOR: **SAMPLE PROJECT**
 Long Island City, NY
 Project: **SAMPLE PROJECT**

3-15-2011

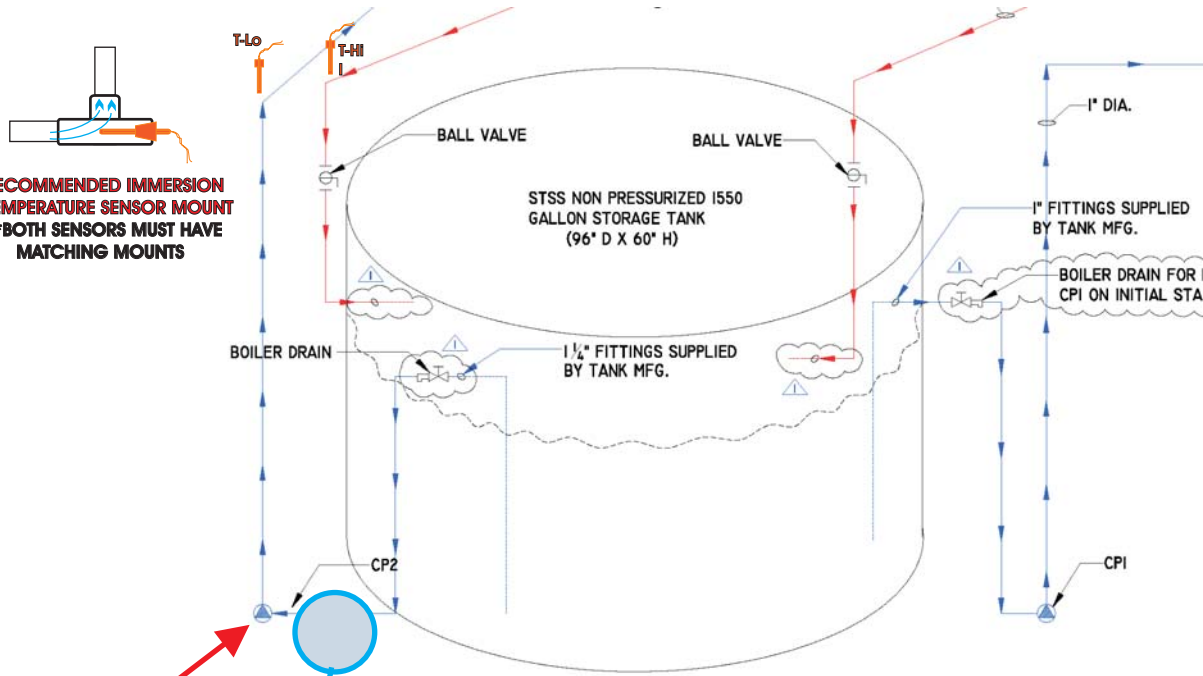

COLLECTOR TO STORAGE PIPING DIAGRAM

RECOMMENDED IMMERSION TEMPERATURE SENSOR MOUNT
****BOTH SENSORS MUST HAVE MATCHING MOUNTS**

TO MINIMIZE TURBULENCE PLEASE NOTE..... THAT THE PUMP IS UPSTREAM OF THE FLOW METER

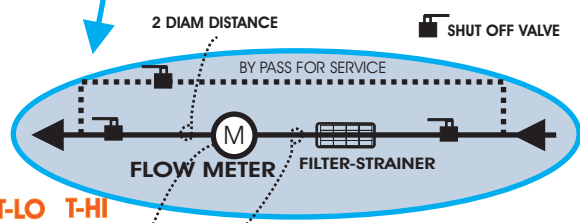

IMPORTANT NOTE
FLOW METER
 TEMPERATURES AND FLOW RATES MUST NEVER BE EXCEEDED AT ANY TIME.

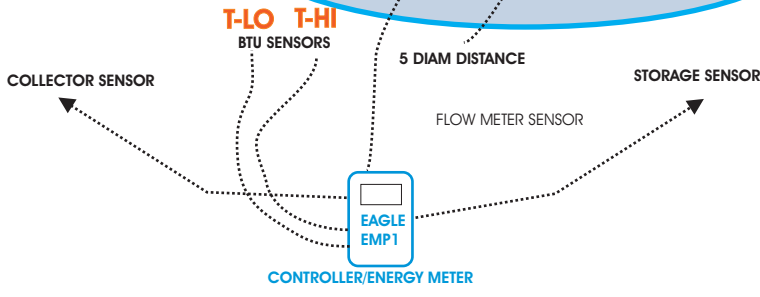

IMC INSTRUMENTS INC
WITTENBERG WI

DESG BY L.F . 715 445 4946
 loui@tds.net

MODEL FLPM-0200 FLOW METER



2 FLOW METER

IMC® INSTRUMENTS, INC.

WITTENBERG WI
8- 07- 2009

PG6

MODEL FLPM-0200 FLOW METER

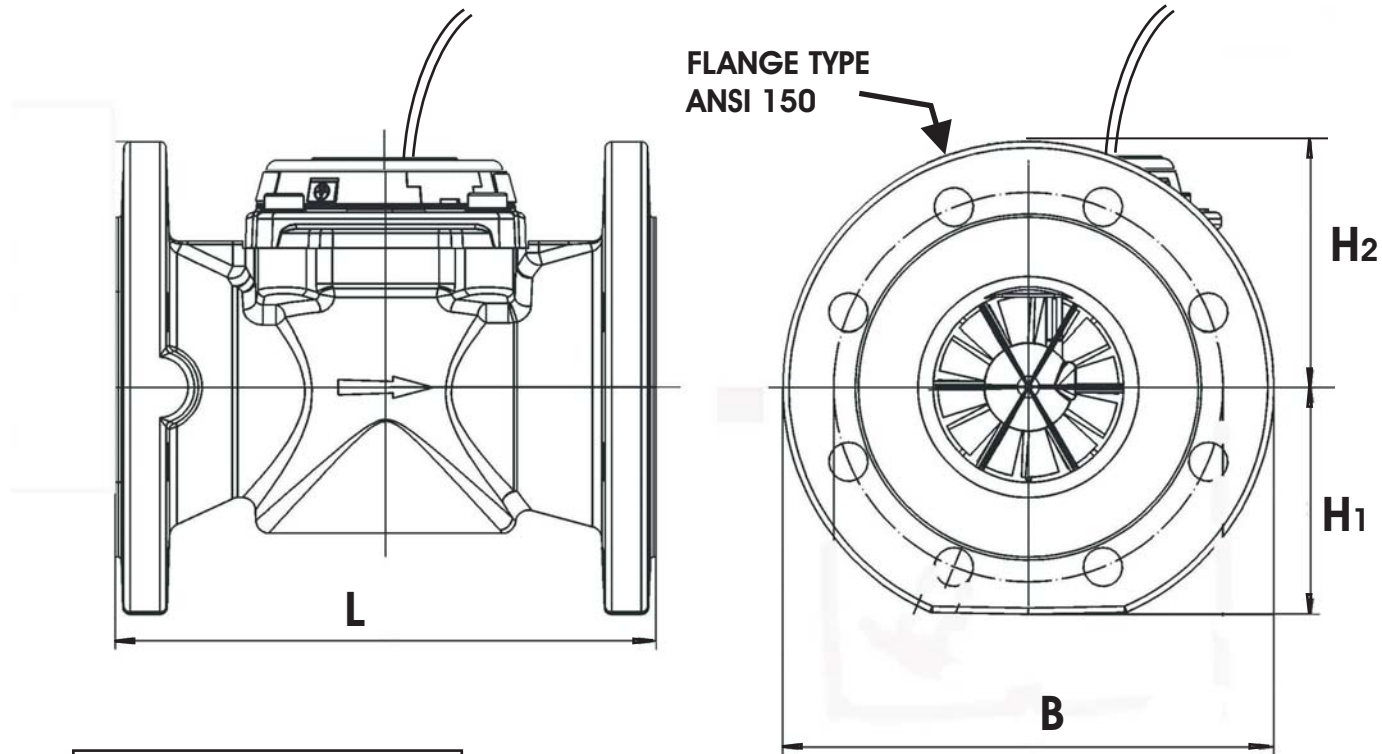

INSTRUMENTS, INC.
www.solar.imcinstruments.com
PRODUCT # FLPM-0200
SIZE: 2 INCH FLANGED; MOUNT
HORIZONTAL / VERTICAL
1.5 min to 66 max GPM CONT.
200 °F MAX; 225 PSI MAX
S/N; CSN
K=2 038 220

L 7 7/8"
B 6 1/8"
H₁ 2 7/8"
H₂ 3 5/8"
WEIGHT 22 LBS

PRESSURE LOSS
 $P_{loss} = 0.0000748 \times Q^2$
 P_{loss}=PSIG , Q=GPM

INSTRUMENTS, INC.

WITTENBERG WI
 02-05-2010

MODEL FLPM-0100 FLOW METER

MODEL FLPM-0150 FLOW METER



1" and 1 1/2" FLOW METERS

IMC[®] INSTRUMENTS, INC.

WITTENBERG WI

02- 05- 2010

PG8

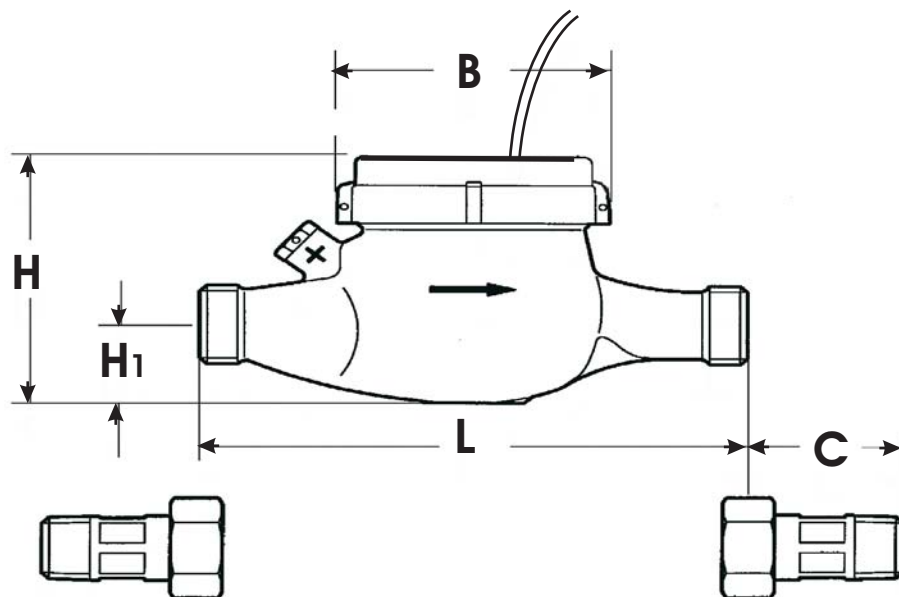

MODEL FLPM-0100 FLOW METER

MODEL FLPM-0150 FLOW METER

L 10 1/4"
B 3 5/8"
H₁ 1 7/8"
H 3 3/8"
C 2 5/8"
WEIGHT 6 LBS

PRODUCT # FLPM-0100
www.solar.imcinstruments.com
 SIZE: 1 INCH NPT; MOUNT
 HORIZONTAL with THIS SIDE UP
 0.5 min to 14 max GPM CONT.
 200 °F MAX; 150 PSI MAX
 S/N # ; CSN #
 K=0913

L 11 3/4"
B 4 3/4"
H₁ 1 7/8"
H 3 3/8"
C 2 7/8"
WEIGHT 12 LBS

PRODUCT # FLPM-0150
www.solar.imcinstruments.com
 SIZE: 1-1/2 INCH NPT; MOUNT
 HORIZONTAL with THIS SIDE UP
 0.8 min to 24 max GPM CONT.
 200 °F MAX; 150 PSI MAX
 S/N #; CSN #
 K=1302

MAX RECOMMENDED FLOW @ LOW WEAR=7.5GPM

MAX RECOMMENDED FLOW @ LOW WEAR=20 GPM

PRESSURE LOSS
 $P_{loss} = 0.00456 \times Q^2$
 P_{loss}=PSIG , Q=GPM

PRESSURE LOSS
 $P_{loss} = 0.001546 \times Q^2$
 P_{loss}=PSIG , Q=GPM



WITTENBERG WI
 02-05-2010

MODEL FLPM-0075 FLOW METER



3/4 FLOW METER

 **INSTRUMENTS, INC.**
WITTENBERG WI
8- 07- 2009

PG10

MODEL FLPM-0075 FLOW METER

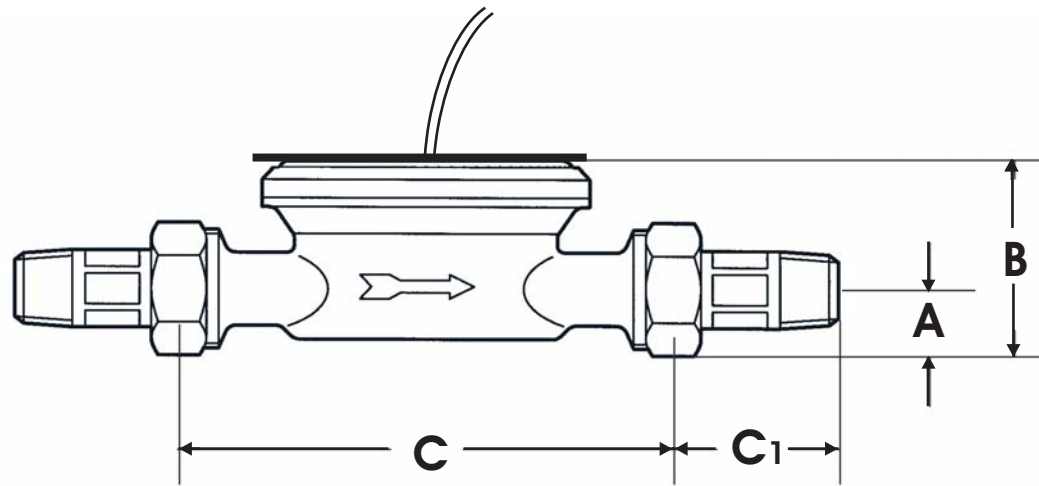

IMC[®]
INSTRUMENTS, INC.
www.solar.imcinstruments.com
PRODUCT # FLPM-0075
SIZE: 3/4 INCH NPT; MOUNT
HORIZONTAL / VERTICAL
0.2 min to 7 max GPM CONT.
200 °F MAX; 150 PSI MAX
S/N #; CSN #
K=202

A 1/4"
B 1 5/8"
C1 2 1/8"
C 5 1/8"
WEIGHT 1.5 LBS

PRESSURE LOSS
 $P_{loss} = 0.0287 \times Q^2$
 $P_{loss} = \text{PSIG}, Q = \text{GPM}$

IMC[®]
INSTRUMENTS, INC.

WITTENBERG WI
02-05-2010

MAX RECOMMENDED FLOW @ LOW WEAR=3.5GPM

PG11



INSTRUMENTS, INC.

468 Liberty Dr.
Wittenberg, WI, 54499,
USA

TEL 715- 253 2801
715- 445 4946
FAX 715- 253 2811

SET UP INSTRUCTIONS

Dated 02-15-2010

IMC EAGLE 2 DIFFERENTIAL CONTROLLER / ENERGY METERS

For the proper installation of the Thermal Energy meter please insure that the following Installation Documents have been reviewed and carefully followed:

- 1) Flow meter INSTALLATION instructions
- 2) Eagle 2 WEB CONTROLLER General description and INSTALLATION instructions

The “Energy Meter feature” of the combination Solar Differential Controller/Energy Meter requires two system components to be carefully set up and verified for proper operation as follows:

1) The **TWO DIFFERENTIAL TEMPERATURE SENSORS** which have been matched to each other to an accuracy of 0.2 degrees F. They have to be kept together as they have calibration numbers in their lead wires that identify their nominal matching numbers. Sensors from other production batches can not be used for this purpose unless they have identical calibration numbers. Sensor matching was tested and verified over the range of 80F to 210F in our precision temperature baths for each set of sensors supplied with each BTU / CONTROLLER. Connecting cables to both sensors have to be matched with in 1.5 ohms of each other in the field. Maximum allowable cable lengths are 18Ga.=75' max, 20Ga.=35' max and 22Ga.=20' feet max. When connecting the sensors to the energy Meter, the HI-sensor must be connected to AUX1 terminals and the LO-sensor to the AUX2 terminals. Insure that the sensors are measuring only the fluid flow temperatures and are not affected by local surrounding temperatures.

2) The **Plug and Play Flow Meter** must be properly installed and protected of debris in the fluid with the use of filter strainers. The flow meter is furnished with a matching PROCESSOR and requires no additional set up. Just make sure that the male/female connectors are FIRMLY brought together until an engaging click is felt. Proper operation can be verified when there is fluid flow by observing ON and OFF flashing of the “in-line” BLUE LED located in the connecting cable. After a maximum of 17 seconds the flow GPM will be displayed in the Energy meter LCD window. Make sure that the display is paged to the proper GPM window.

For the final operation of the Energy meter the LCD display can be paged to the Kilo-Watt Hour page to view the TOTALIZED energy in KWH with a resolution of 1/10ths of a KWH. This reading can be reset to ZERO by pressing and holding down the paging button for 33 seconds until the KWH reading shows 000000.0.

IMC FLOW METERS MODELS FLPM & FLPH

INSTALLATION AND OPERATING INSTRUCTION Rev. 1-11-2010

1) Prior to installation please confirm that the system TEMPERATURE and PRESSURE DO NOT EXCEED the NAME PLATE RATING. The maximum flow specified for the meter should also never be exceeded as excessive wear may occur.

2) It is recommended that UNIONS and SHUT OFF VALVES be installed upstream and downstream of the flow meter to allow for service and removal of the flow meter. IF the meter is to be temporarily removed a piece of straight pipe can be installed in its place until the meter is serviced and returned back into operation.

3) To insure that only clean liquid enters the flow meter it is HIGHLY recommended that a STRAINER be installed upstream of the meter inlet. In addition to the above it is also recommended that the system be flushed thoroughly after any plumbing changes. The use of Pipe tape is discouraged in lieu of TFE plumbers compound thread paste to avoid loose tape from entering the fluid stream.

4) When installing the flow meter pay careful attention that the direction of flow matches the arrow on the body of the flow meter. The flow meter body is to be mounted with the name plate facing UP. The only exception to this is when vertical mount is permitted and is clearly shown on the name plate of the flow meter. If vertical mount is permittedFLOW CAN NOT BE DOWN !!!!!!!!!!!

5) For the 1/2" and 3/4" flow meters there is a requirement to have at least 5 pipe diameters of STRAIGHT pipe in order to achieve rated accuracy. For Meters 1" and larger a 3 pipe diameter will meet this requirement.

6) EXTRA SPECIAL ATTENTION should be paid in PREVENTING the flow meter from being exposed to WATER HAMMER as well as FREEZING fluids. Damage will occur

Any questions should be directed to:

Attn. Flow meter dept.
IMC Instruments, Inc.
468 Liberty Drive
Wittenberg, WI 54499
(715) 445-4946